

Material:	Suffix
Steel - unhardened -	.10
Steel - case hardened zinc plate yellow passivate -	.16
Stainless Steel - 1.4105 (Ferritic) -	.40
Stainless Steel - 1.4305 (Austenitic) -	.50

Description: The Pin Lok insert functions in a similar manner to the 'H' Type insert but incorporates an additional locking feature which is produced by a grooved pin driven down the side of the insert after insertion. A groove is milled down the length of the insert. A 2mm diameter hole is drilled at this point and the pin pressed into position.

Application: The Pin Lok insert gives ultimate torque and vibration resistance and is used in explosion proof mining equipment.

Part number example: **318 0 050 .16**
Tappex Pin Lok insert - Steel, case hardened zinc plate yellow passivate - regular.

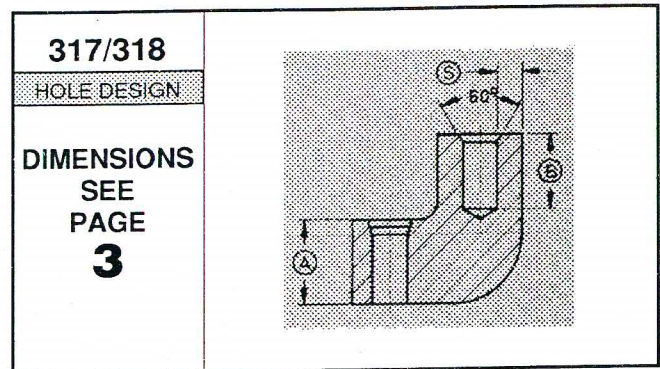
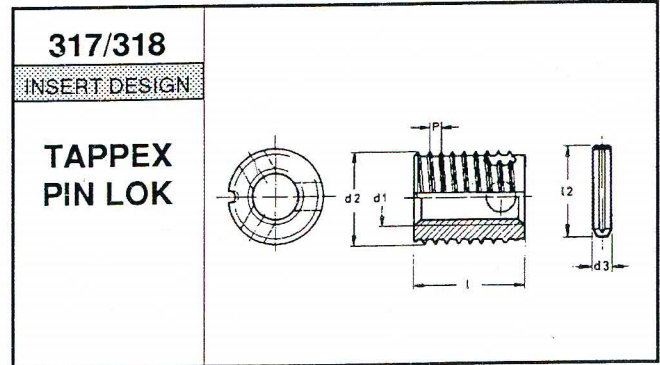

PART NUMBER	INTERNAL THREAD d1	EXTERNAL THREAD		LENGTH l	MINIMUM HOLE DEPTH (DRILLED HOLES)	MINIMUM MATERIAL THICKNESS (THROUGH HOLES)	WEIGHT PER 100 PCS Kg. (+/-3%)	GROOVED PIN	
		d2	P					l2	d3
317 0 040..	M 4	6,5	0,8	6	8	6	0,069	4	2
318 0 040..				8	10	8	0,102	6	2
317 0 050..	M 5	8	1	7	9	7	0,120	4	2
318 0 050..				10	13	10	0,179	6	2
317 0 060..	M6	10	1,25	8	10	8	0,222	6	2
318 0 060..				12	15	12	0,362	10	2
317 0 080..	M 8	12	1,5	9	11	9	0,325	6	2
318 0 080..				14	17	14	0,525	10	2
317 0 100..	M10	14	1,5	10	13	10	0,430	6	2
318 0 100..				18	22	18	0,845	16	2
317 0 120..	M12	16	1,75	12	15	12	0,636	10	2
318 0 120..				22	26	22	1,247	16	2
317 0 140..	M14	18	2	14	17	14	0,897	10	2
318 0 140..				24	28	24	1,640	16	2
317 0 160..	M16	20	2	14	17	14	1,011	10	2
318 0 160..				24	28	24	1,857	16	2

All dimensions are in millimetres unless specified. 317 - SHORT. 318 - REGULAR